

# Z21 & Z25 SERIES



Muncie®  
Power  
Products



FOR

# RAM

3500 | 4500 | 5500

TORQUEFLITE HD | ZF POWERLINE

# Z225 SERIES

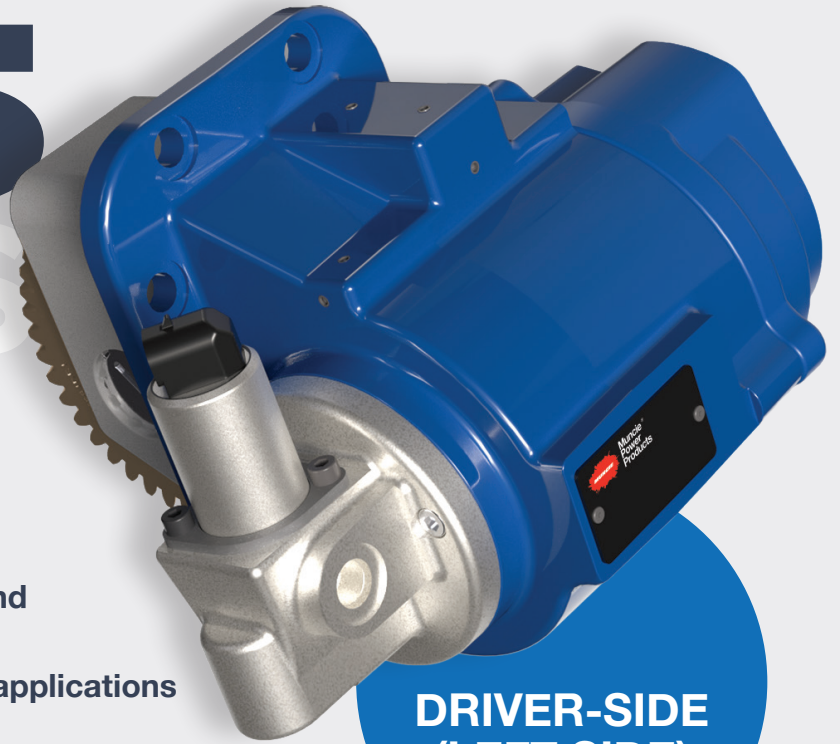

## KEY FEATURES

- Light-duty, clutch shift PTO for TorqueFlite HD/ZF PowerLine
- Designed for PF4 Series gear pumps and FX Series piston pumps
- Allows for direct mount pumps on 4x4 applications
- Round keyed output also available
- Single ratio option—145% of engine speed
- 125 lbs. ft. torque rating
- Intermittent/continuous 24 HP @ 1,000 RPM

**DRIVER-SIDE  
(LEFT-SIDE)  
ONLY**

ON RAM APPLICATIONS

## BENEFITS

Different port sizes on activation and switch ports

Integral solenoid

Single gasket—  
no measuring  
backlash

Low-profile housing

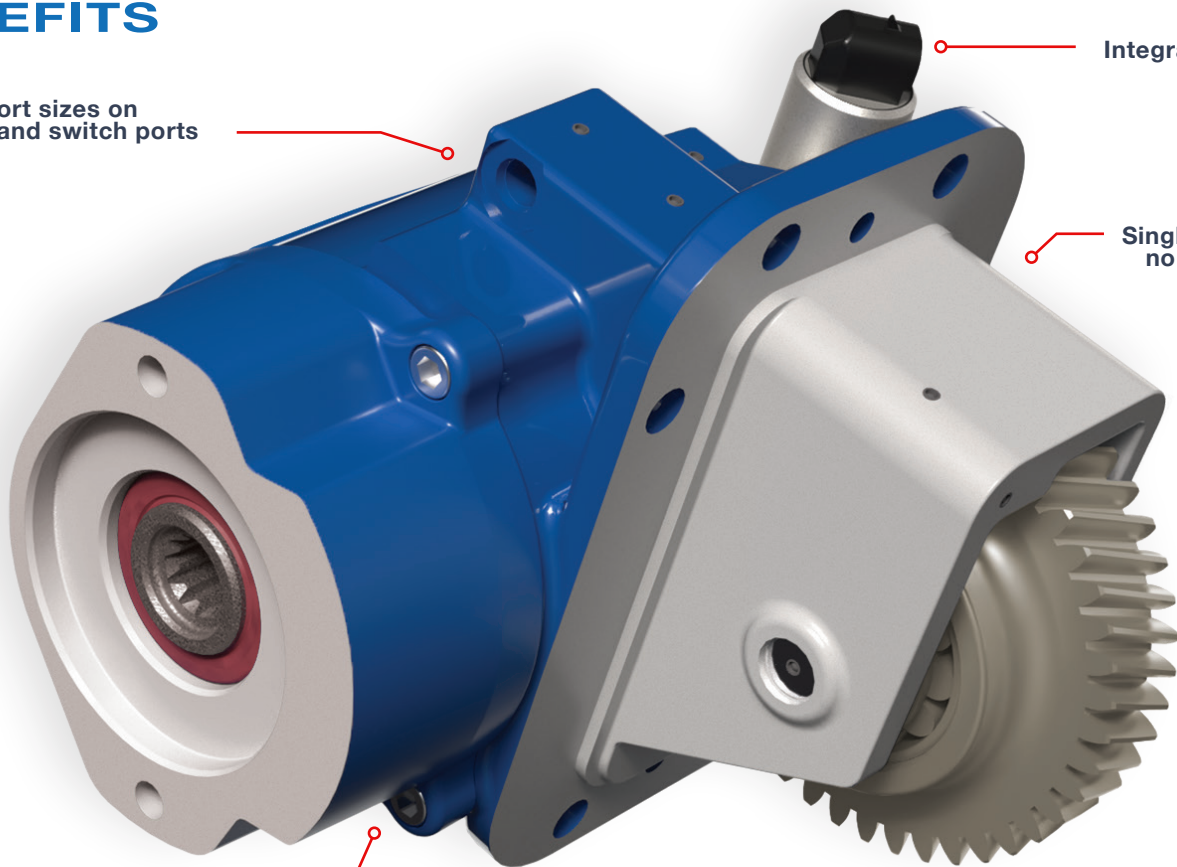

# MODEL NO. CONSTRUCTION

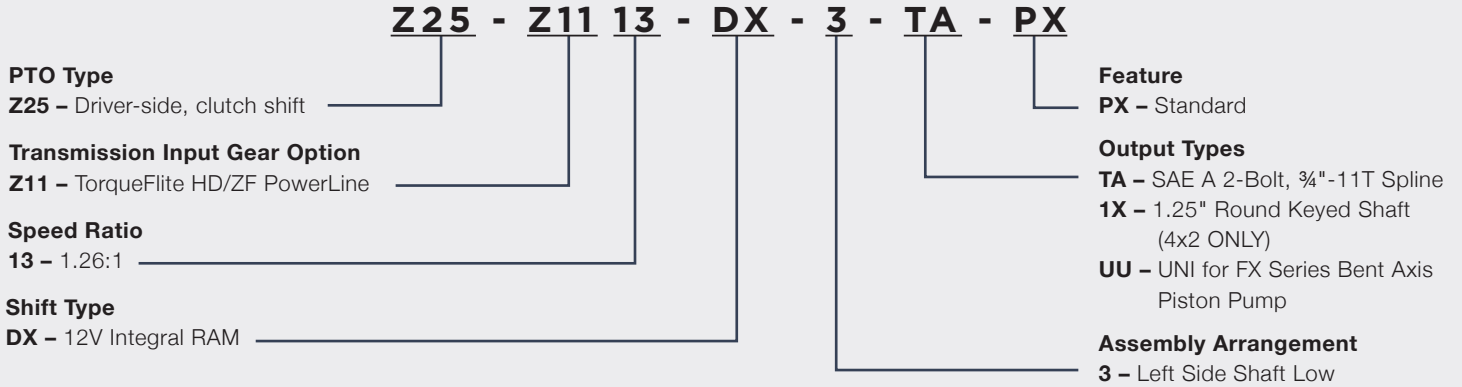

# COMPATIBLE PUMP CAPABILITIES

WHEN PAIRED WITH THE Z25 SERIES PTO

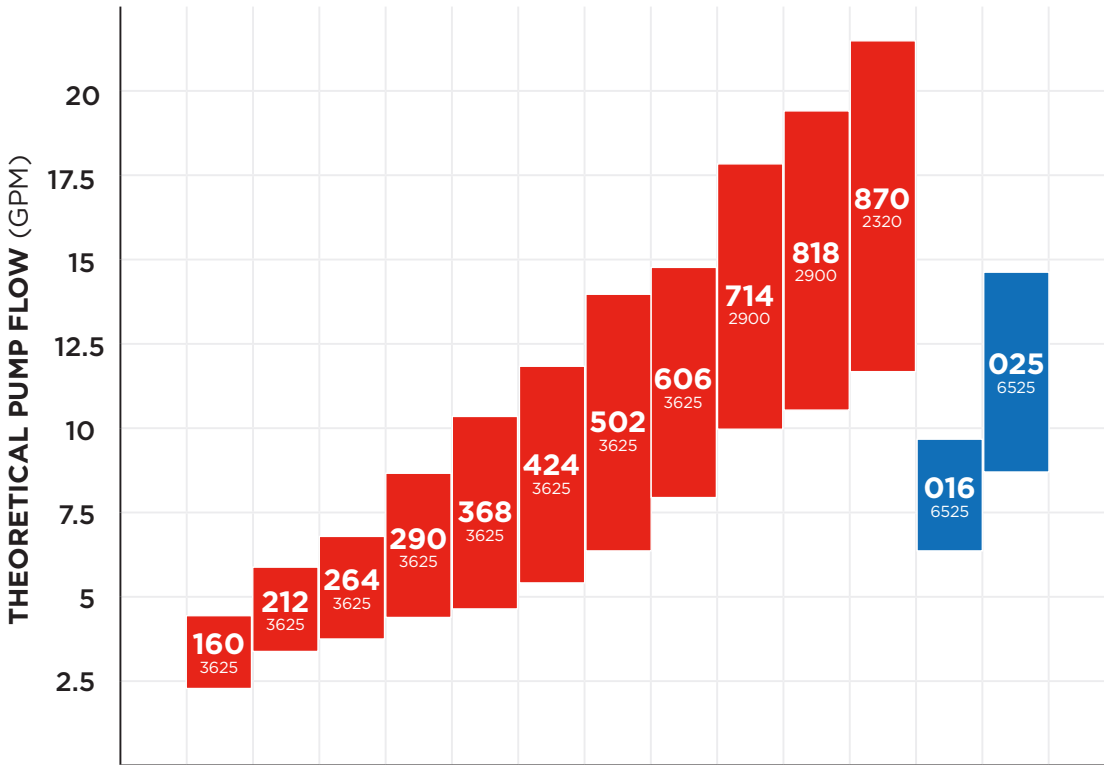

**LEGEND:**

Theoretical flow @ 1,900 engine RPMs →

Pump Model → **502**

Max. PSI → 3625

Theoretical flow @ 900 engine RPMs →

**Example:**  
PF4-502

\* PF4-606 through PF4-870 models have a max. engine RPM of 1,700

\*\* 24FXG-016 and 24FXG-025 models have a max. engine RPM of 1,500

**PF4 SERIES\***



**FX SERIES\*\***

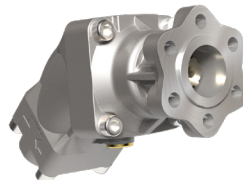

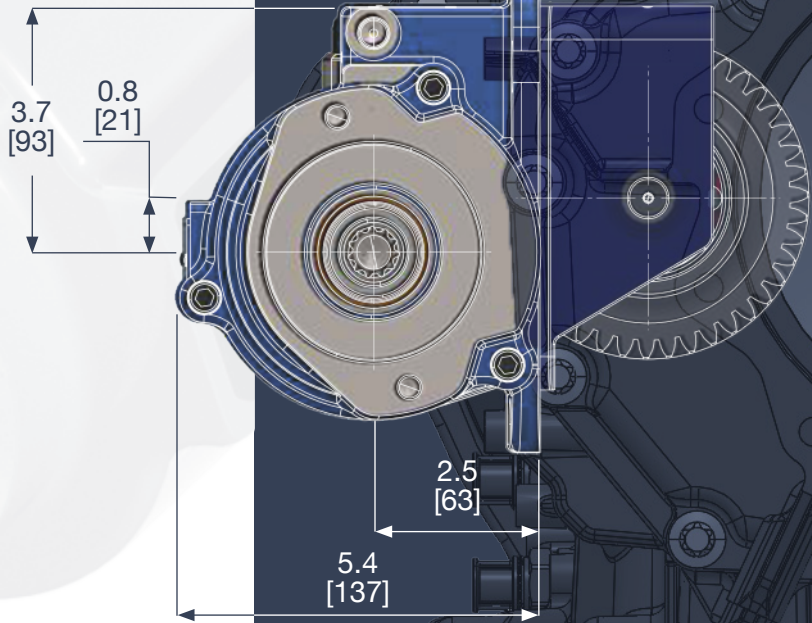
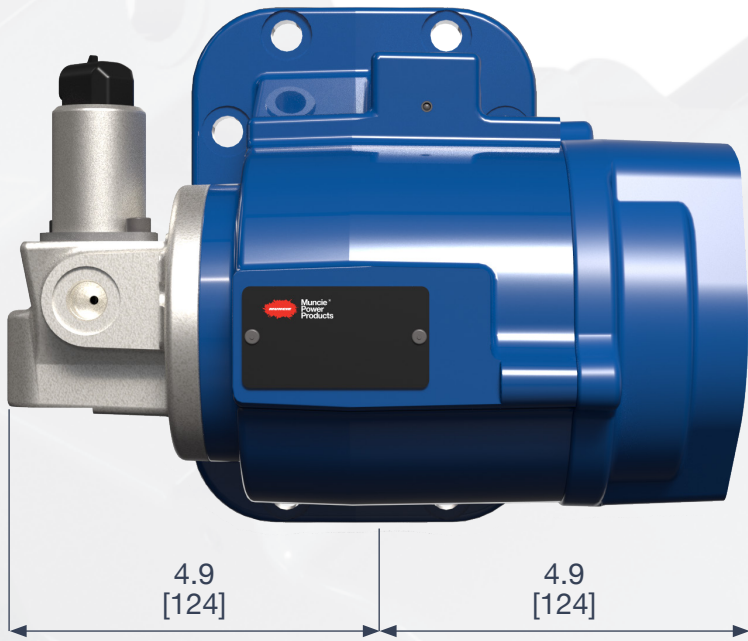

# Z225

# EAS

# INSTAL

# Z225

# SERIES

FOR

# RA

3500 | 45

TORQUEFLITE HD

# & Z21 SERIES LATION

# Z21 SERIES

# AM

## 00 | 5500

### ZF POWERLINE

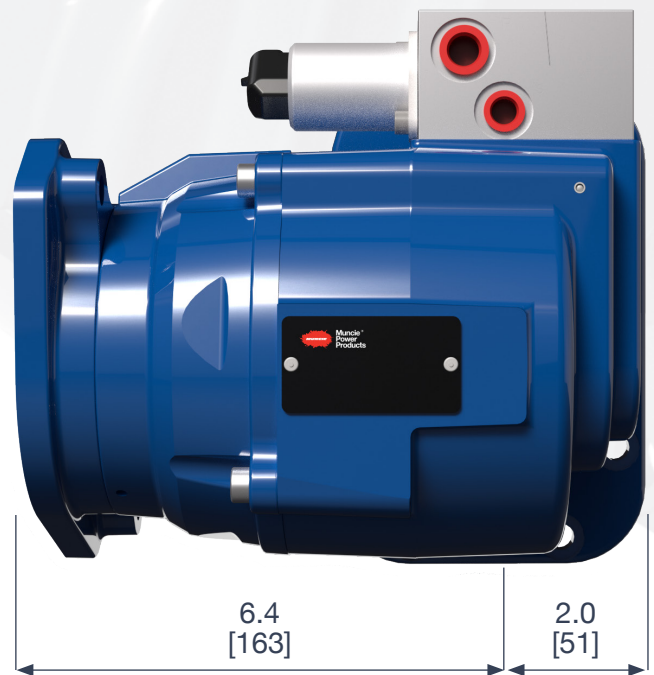
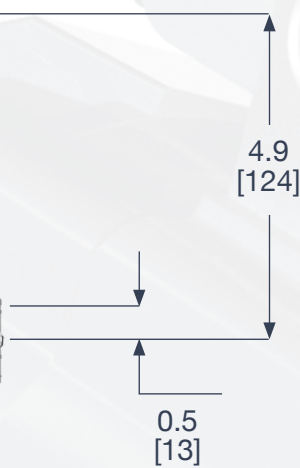
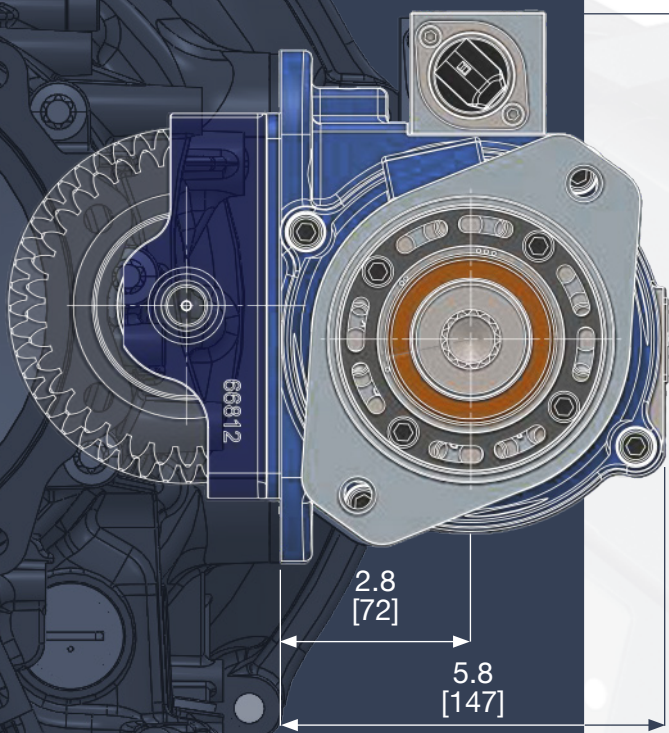

6.4  
[163]

2.0  
[51]

# Z21 SERIES

## KEY FEATURES

- Medium-duty, clutch shift PTO for TorqueFlite HD/ZF PowerLine
- Rotatable pump flange
- Single ratio option—130% of engine speed
- 265 lbs. ft. torque rating
- Intermittent/continuous 50 HP @ 1,000 RPM



**PASSENGER-SIDE  
(RIGHT-SIDE)  
ONLY**

ON RAM APPLICATIONS

## BENEFITS

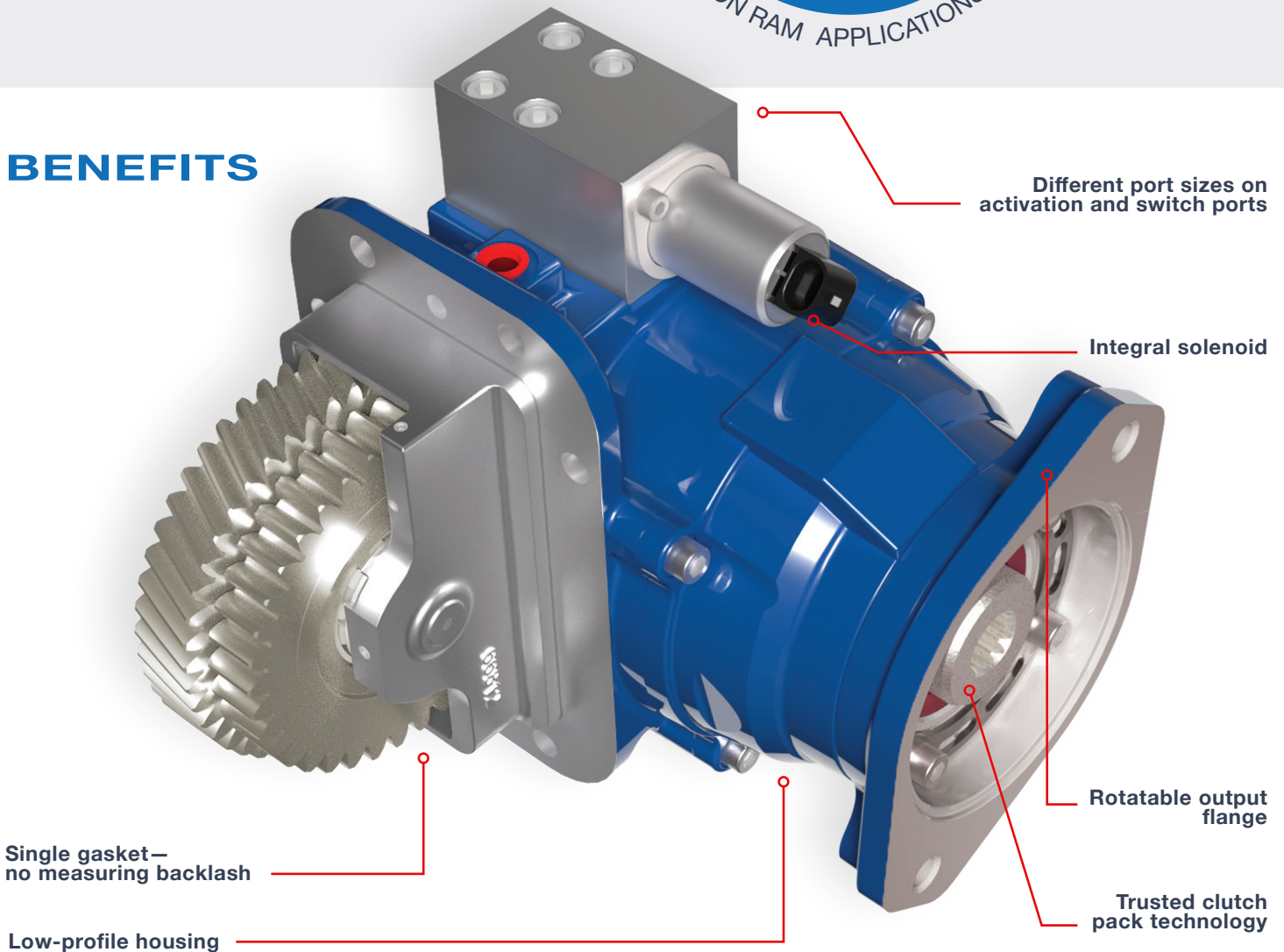

Different port sizes on activation and switch ports

Integral solenoid

Rotatable output flange

Trusted clutch pack technology

Single gasket—no measuring backlash

Low-profile housing

# MODEL NO. CONSTRUCTION

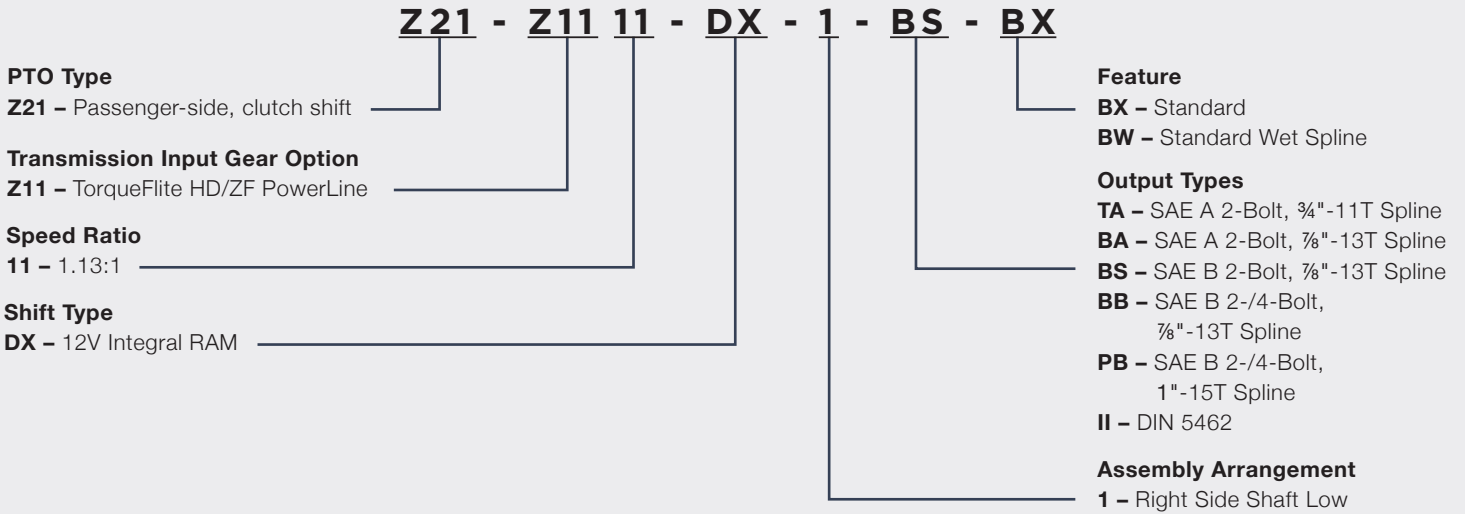

# COMPATIBLE PUMP CAPABILITIES

WHEN PAIRED WITH THE Z21 SERIES PTO

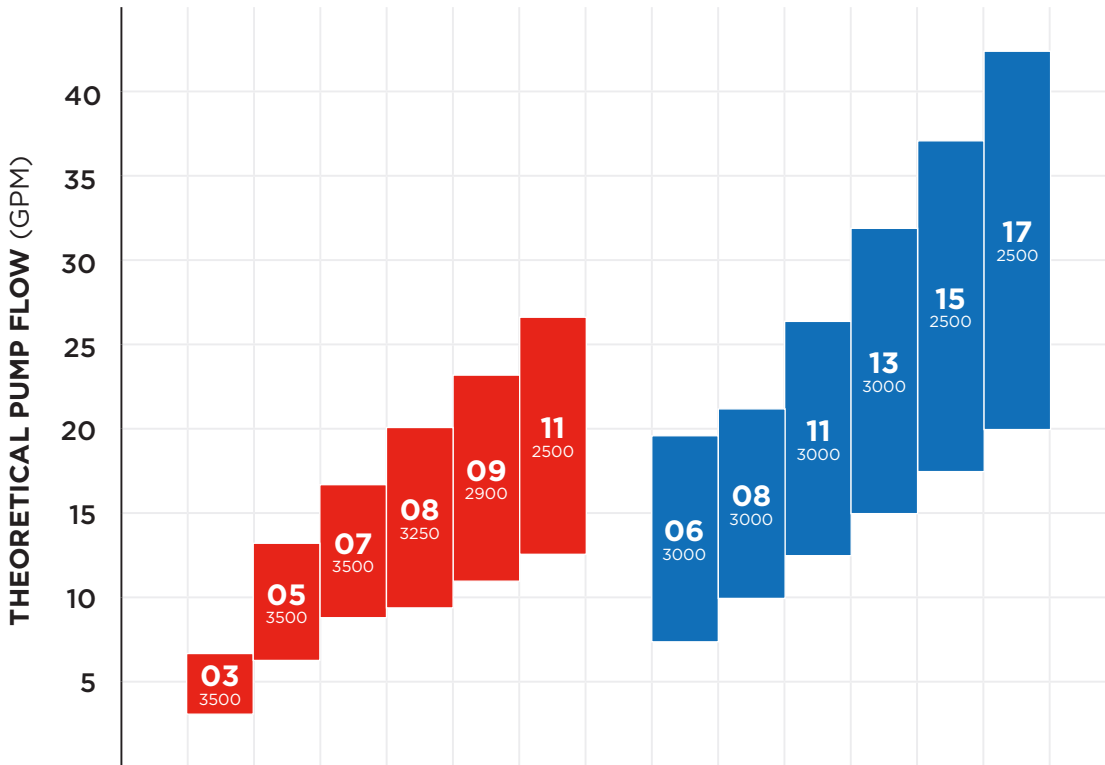

**LEGEND:**

Theoretical flow @ 1,900 engine RPMs → [Red bar]

Pump Model → 11

Max. PSI → 2500

Theoretical flow @ 900 engine RPMs → [Red bar]

**Example:**  
PH1-11

**PH SERIES**



**PK SERIES**





**Muncie<sup>®</sup>  
Power  
Products**

*A Member of the Interpump Group*

MI24-22 (Rev. 03-25)

201 East Jackson Street, Muncie, Indiana 47305  
800-367-7867 • Fax: 765-284-6991 • [info@munciepower.com](mailto:info@munciepower.com)  
Specifications are subject to change without notice.  
Visit [www.munciepower.com](http://www.munciepower.com) for warranties and literature.  
All rights reserved. © Muncie Power Products, Inc. (2024)