



INSTALLATION NOTES

1. Disconnect the negative battery cable. Remove the three bolts holding the fan shroud to the engine braces. Remove the four nuts from the fan clutch and remove the fan and fan clutch assembly from the engine. Loosen and remove the alt. belt and A/C belt if equipped. Remove the fan clutch mounting plate from the water pump.
(Do not remove the pulley).
2. Remove the four bolts holding the crank pulley on the crankshaft. (It may be necessary to use an impact to remove the bolts). Clean any dirt or rust from the inside of the OEM pulley. Install the drive pulley (1) using four 16mm bolts (2) and lockwashers (3). Tighten securely. Install the aluminum fan spacer (4) and the OEM fan clutch adapter onto the water pump using bolts (5) and lockwashers (6).
3. Before the pump bracket (7) can be installed a boss on the front of the engine block (approx. 1") must be removed. This can be done using a hacksaw etc. (See illustration)
4. Remove the O.E.M. alternator. Remove the lower alternator bracket. Remove the front two motor mount bolts. Install the pump mounting bracket (7) and spacer plate (8) onto the engine block at that location using bolts (9) and lockwashers (10). Install new lower alternator bracket (11) as shown in the illustration using O.E.M. bolts. Install the alternator on the new lower alternator bracket (11) using the O.E.M. bolt and nut. Install the O.E.M. belt(s). Install the pump (14) onto the bracket (7) with bolts (15), lockwashers (16), and nuts (17). Install the tensioner (12) with bolt (13). Install the coil adapter plate (18) with bolts (19). Install the coil and clutch as per manufacturer's instructions. Install pump drive belt (25).
5. Install the fan onto the water pump with the four OEM nuts. Using the 1/2 spacers, move the fan shroud ahead and hold in place with bolts provided. **NOTE:** The fan shroud brace on the lower passenger side will need to be removed and a nylon strap is used to hold it in place. Connect the negative battery cable. Check for clearance on all hoses, wires, etc.

CMKI11-5200-ZP8-AC

2011-2025 Isuzu

NPR-HD/NQR/NRR

5.2L Diesel W-W/O AC

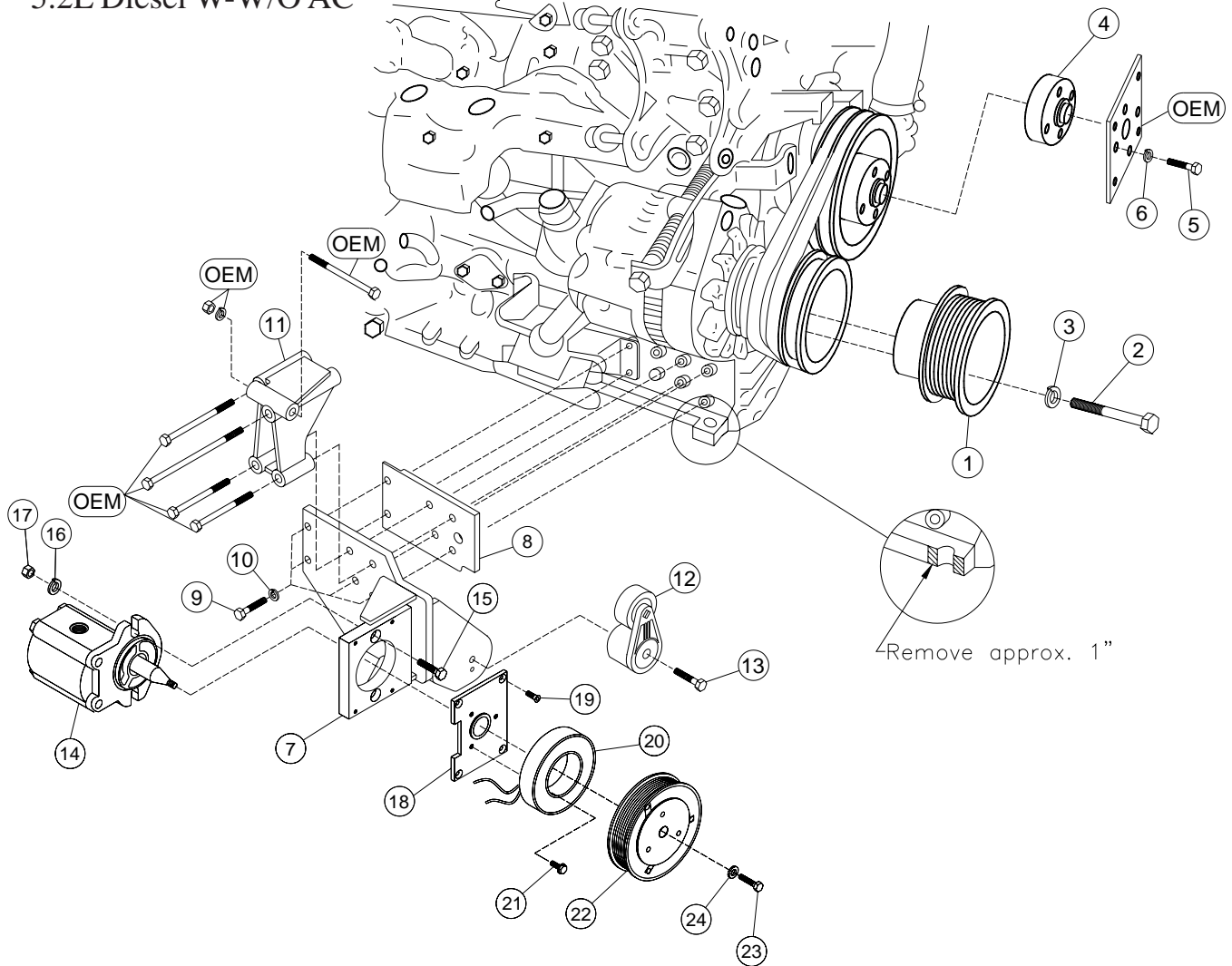

PARTS LIST

- | | |
|------------------------------------------|----------------------------------------------|
| 1. SPC 2308 (1) | 15. 3/8 x 1-1/2 NC (2) |
| 2. 16mm x 100mm 1.5 (4) | 16. 3/8 LW (2) |
| 3. 16mm LW (4) | 17. 3/8 NC (2) |
| 4. FSO 4.7 (1) | 18. MCA01 Clutch Mtg Plate (1) |
| 5. 8mm x 35mm 10.9 (4) | 19. 1/4 x 3/4 NC FHSCS (4) |
| 6. 8mm LW (4) | 20. Coil (Sold Separately) (1) |
| 7. SMP 230A-8 (1) | 21. Capscrew-19T34530 (3)
(t=8-10 ft/lbs) |
| 8. SPS 33 (1) | 22. Clutch (Sold Separately) (1) |
| 9. 10mm x 40mm 10.9 (4) | 23. Capscrew-19T38756 (1)
(t=20 ft/lbs) |
| 10. 10mm LW (4) | 24. Flat Washer-21MZ3487 (1) |
| 11. SMB 2301 (1) | 25. Belt: 5080400 Dayco |
| 12. 89231TIPCS (1) | |
| 13. 10mm x 55mm (1) | |
| 14. Clutch Pump (1)
(Sold Separately) | |