



MESP-300A

INSTALLATION INSTRUCTIONS AND OWNER'S MANUAL

FEATURES • INSTALLATION • OPERATION • CALIBRATION • SERVICE



TABLE OF CONTENTS

<u>DESCRIPTION</u>	<u>PAGE</u>
Features and Description.....	3
Specifications.....	3
Spreader System Components.....	4
Complete Spreader Packages.....	5
Wire Harness and Pin-outs.....	6
Controls and Displays.....	7
Operation Instructions.....	7-8
Calibration Menu.....	9-10
Troubleshooting.....	11

FEATURES AND DESCRIPTION

- Auto and manual operation
- Nine levels of auger control
- Nine levels of spinner control
- Blast mode
- Pause mode

The MESP-300A spreader controller provides manual and automatic spreader operation. In auto mode the MESP-300A maintains a constant pound per mile spreader rate as the vehicle's speed varies. The controller will drive two electrohydraulic proportional flow control valves; conveyor (auger) and spinner. The MESP-300A's valve control is fully adjustable with minimum and maximum trim settings.

The MESP-300A's front panel incorporates two rate controls for the auger and spinner operation. Both settings are reported to the operator from digital displays located directly above the rate controls. For Pass and Blast simply push each button.

SPECIFICATIONS

OPERATING VOLTAGE

- 11 – 15VDC

OUTPUTS

- Two (2) voltage controlled PWM valve drivers
- 2200 mA max
- 100 hZ pulse width modulation
- Short and open circuit protection

INPUTS

- Groundspeed Input (0 – 2.5 kHz square or sine wave)

FRONT PANEL

- Two (2) seven segment rate displays
- Two rate controls
- Blast and pause buttons

CALIBRATION

- All calibrations are set via the front panel, no tools required.

SYSTEM COMPONENTS

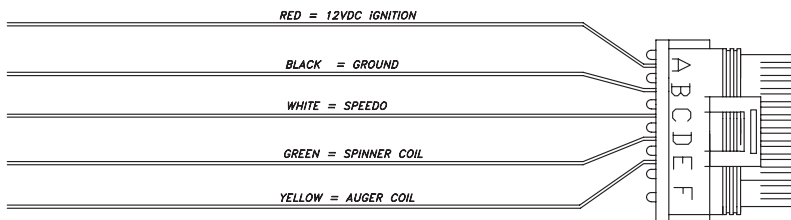
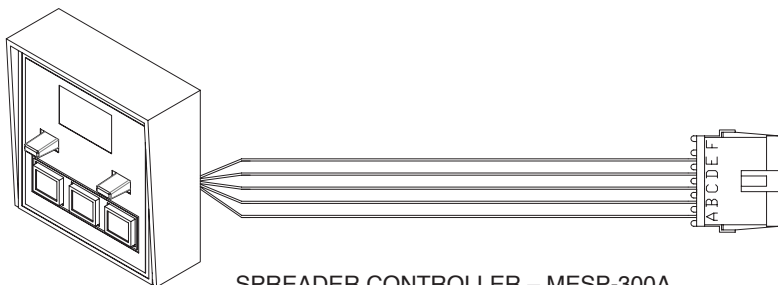

WIRE HARNESS – MESP-303A
(SOLD SEPARATE)

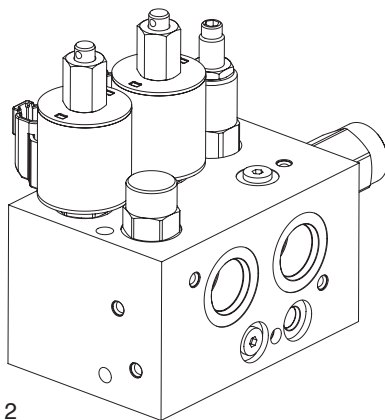

COMPLETE PACKAGES

NO ENCLOSURE

MESP3016F

Includes the following:

- MESP-300A – Controller
- MESP-303A - Harness
- HF68416-12 – Open Center Manifold

MESP3017F

Includes the following:

- MESP-300A – Controller
- MESP-303A - Harness
- HF68416-12 – Closed Center Manifold

WITH ENCLOSURE

MESP3016FASM

Includes the following:

- MESP-300A – Controller
- MESP-303A - Harness
- HF68416-12 – Open Center Manifold
- Plus Enclosure

MESP3017FASM

Includes the following:

- MESP-300A- Controller
- MESP-303A - Harness
- HF68416-12 – Closed Center Manifold
- Plus Enclosure

MESP3016FASM



PIN-OUTS

CONTROLLER HARNESS – MESP-303A

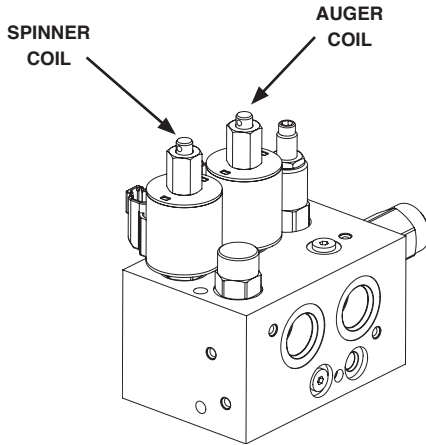
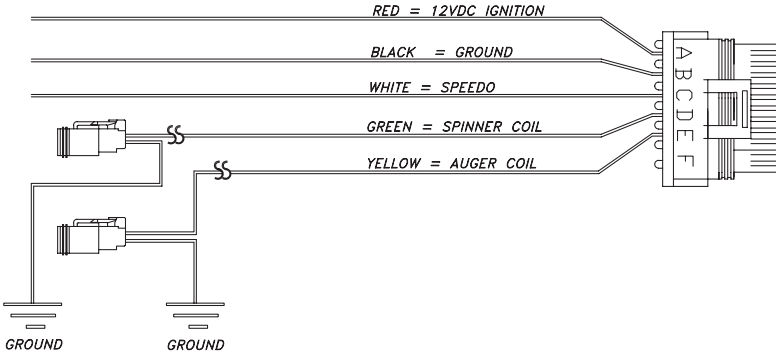

HF68416-12

PIN #	WIRE COLOR	CONNECT TO
A	RED	12VDC
B	BLACK	GROUND
C	WHITE	SPEEDOMETER
D	GREEN	SPINNER COIL
E	YELLOW	AUGER COIL

CONTROLS AND DISPLAYS

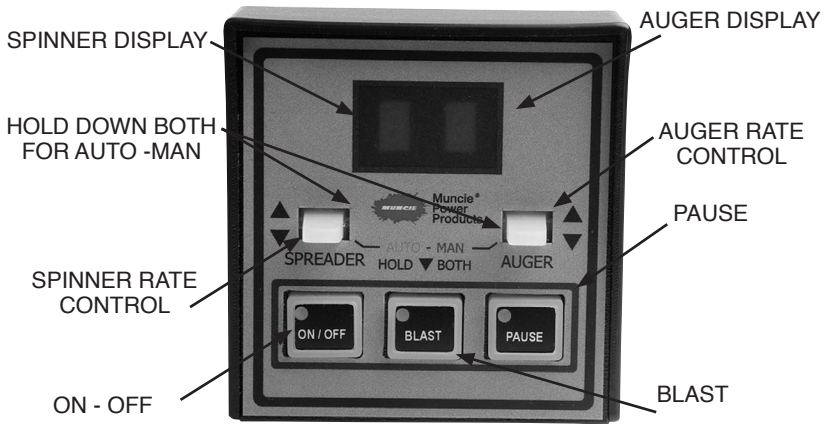

OPERATION INSTRUCTIONS - CONTROLS

ON-OFF

Press the On – Off button to power controller

SPINNER RATE CONTROL

Actuate up to increase and down to decrease the rate

AUGER RATE CONTROL

Actuate up to increase and down to decrease the rate

BLAST

Press the blast button to increase auger output to the maximum trim setting. Once released blast will continue for a 5 second interval. Repress the blast during the 5 second timed interval to cancel the blast operation. Hold the blast button for infinite operation. The numerical value “9” will show on the auger display while the system is in blast mode.

PAUSE

Push and release the button to pause the operation of the auger and spinner. Push and release again to resume operation at the original settings. The letter “P” will flash on the screen while the system is paused.

SWITCHING MODES

Hold both rate controls down for 4-5 seconds. The rate controls will flash 2-3 times and change colors to indicate switching between operating modes.

Auto Mode = Green rate controls

Manual Mode = Red rate controls

OPERATION INSTRUCTIONS

AUTO MODE OPERATION

In auto mode the truck speed (MPH) is used to automatically increase / decrease the auger rate to constant pounds per mile output.

- In auto mode, the auger rate adjustment has (10) settings. (0-9) (0 = off). As the auger rate is increased, the auger will discharge more material per lane mile.
- The Auger will automatically halt at 0 MPH in auto mode. The Auger display will continuously flash at 0 MPH – or – loss of a speedometer input if truck is moving.
- Auto Mode does not proportionally affect the spinner rate like the auger. This is set by the operator and remains constant at all MPH speeds.

MANUAL MODE OPERATION

In manual mode the auger rate adjustment has (10) settings. (0-9) (0 = off)

- Each increment changes the auger speed by approximately 10%, each setting will produce a constant auger speed at all MPH. Therefore as MPH increases for any given auger rate, the actual pounds per mile will decrease; also, unlike auto, the system will not automatically turn off the spreader output when the truck comes to a stop, the operator must use the pause button or turn the auger rate to 0 to manually stop the spreader.

CALIBRATION MENU

SPEEDOMETER SYNCHRONIZING

• If the Auto mode feature is going to be used, the vehicle speed will need to be synchronized with the controller.

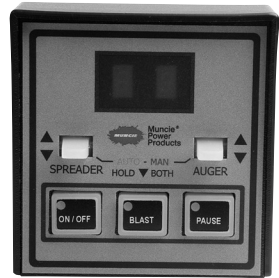

1) Verify controller is receiving a speedometer input:

a) Turn the controller “on”

b) Place the controller in auto mode (green rate controls)

c) In auto mode the auger display will flash whenever the MPH is “0” or there is no speedometer connection. This also indicates the auger is not turning. If the auger display goes steady when the vehicle begins moving the controller is receiving a valid signal. Follow the next steps to sync the speedometer.

2) Syncing the truck speed with the controller

a) With the controller turned off, simultaneously press and hold both the On-Off button and the blast button until the letter “S” appears on the spinner display.

b) Sustain vehicle speed at 20MPH. Once at 20 MPH, press the blast button. The numbers “20” should now flash whenever the controller is between 3-4 MPH of 20MPH

c) To verify if speedometer calibration took, slow vehicle to below 15 MPH and accelerate back up to 20 MPH. Once vehicle speed increases to 20MPH, display will change from S to 20 and flash.

TRIM SETTING ADJUSTMENT

• The trim setting adjustment determines the minimum and maximum current to both the auger and spinner valves. The minimum current is critical to the operation of both the auger and spinner. All valves have a threshold (minimum) current that must be met before the valve will open to generate hydraulic flow. By accurately setting the minimum currents, the MESP 300A will always start its control output at this level and not at a lower value that would result in no spreading at low MPH.

• The auger and spinner max settings will establish the maximum operation speed. This will restrict the maximum speed in both Auto and Manual Modes.

WARNING! When you access the Trim Setting Menu, the auger and spinner operation is live.

CALIBRATION MENU

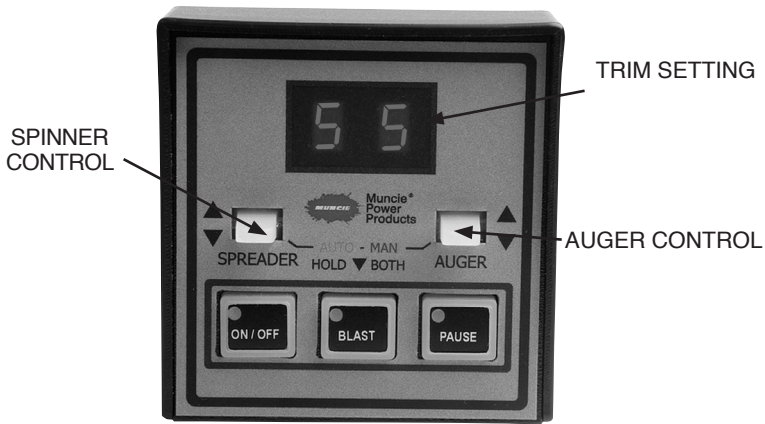

Accessing the Menu:

- 1) With the controller off, press the on – off button and the pause button simultaneously until the display flashes 3-4 four times. (Repeat process if both rate controls light)
- 2) Spinner Min - The spinner control should now be the only control lit, and it should be lit green in color to indicate the spinner min setting. Using the spinner control, adjust the numerical value on the display so that the spinner is just barely turning. Press the blast button to lock in the value and continue to the spinner max setting.
- 3) Spinner Max – The spinner control should have turned from green to red after locking in the spinner min setting. Using the spinner control, adjust the numerical value on the display to set the max setting desired for the spinner. Press the blast button to lock in the value and continue to the Auger min setting.
- 4) Auger Min – The auger control will now be the only control lit, and should be lit green in color to indicate adjusting the auger min setting. Using the auger control, adjust the numerical value on the display so that the auger is just barely turning. Press the blast button to lock in the value and continue to the auger max setting.
- 5) Auger Max – The auger control should have turned from green to red after locking in the auger Min. Using the auger control, adjust the numerical values on the display to set the maximum setting desired for the auger. Press the blast button to lock in the setting.
- 6) After setting the Auger max, press the On-Off button to exit the trim setting menu.

* The Minimum Settings cannot be adjusted higher than the maximum setting and the maximum setting cannot be adjusted lower than the minimum setting.

TROUBLE SHOOTING

SYMPTOM	POSSIBLE CAUSE
MESP-300A will not power on.	<ul style="list-style-type: none"> • Check wiring designation, and check inline fuse if installed
Auger - Non Functional	<ul style="list-style-type: none"> • If the rate controls are lit green, the auger is in auto mode and will not function until vehicle begins moving
Auto Mode Non - Functional	<ul style="list-style-type: none"> • If numerical values blink in auto mode while truck is moving, controller is not observing a speedometer input. Verify that speedometer input is connected to a valid speedometer signal. • Speedometer input not properly synchronized with controller. Try recalibrating speedometer input (pg. 8)
Auto Mode does not perform at low MPH	<ul style="list-style-type: none"> • Speedometer input not properly synchronized with controller. Try recalibrating speedometer input (pg. 8) • Set Auger minimum trim setting
Auger or Spinner inoperative in auto and manual mode	<ul style="list-style-type: none"> • Check Wire harness connections, and verify that pins are crimped and seated correctly in the connectors • Check electrical connections to solenoids valves and grounds • Adjust trim settings
No Auger or Spinner operation at low rates	<ul style="list-style-type: none"> • Increase minimum trim settings so that either the spinner or auger just begins to move. This will eliminate the deadband within the valve.



**Muncie®
Power
Products**



Muncie Power Products, Inc. *Member of the Interpump Hydraulics Group*
General Offices and Distribution Center • P.O. Box 548 • Muncie, IN 47308-0548 • (765) 284-7721
FAX (765) 284-6991 • E-mail info@munciepower.com • Web site <http://www.munciepower.com>
Drive Products, Exclusive Agents for Canada, *ISO Certified by an Accredited Registrar*

IN12-01 Printed in the U.S.A.
© Muncie Power Products, Inc. 2012