



KEEP IN VEHICLE
READ OPERATING INSTRUCTIONS
INSIDE BEFORE OPERATING PTO

TG SERIES PTO INSTALLATION

**FOR GENERAL MOTORS 3600 CAB CHASSIS WITH
ZF S6-650 MODEL MANUAL TRANSMISSION
MODEL YEAR 2001-2006
INSTALLATION REQUIRING PTO HEAT SHIELD**

Use this manual in conjunction with PTO Manual IN84-03 enclosed with PTO.

(Contact a Muncie customer service representative for PTO application on other GM chassis with manual transmissions.)



PTO INSTALLATION ZF MANUAL 6 SPEED

1. READ WARNING ON INSIDE OF FRONT COVER OF THE PTO INSTALLATION AND OWNER'S MANUAL INCLUDED WITH THIS PTO.
2. Read PTO installation Manual IN84-03 included with PTO before getting started. Section one of the IN84-03 applies to all PTO installations including this PTO.
3. Allow Engine and exhaust system to cool before beginning installation.
4. Remove exhaust on gas engine vehicles.

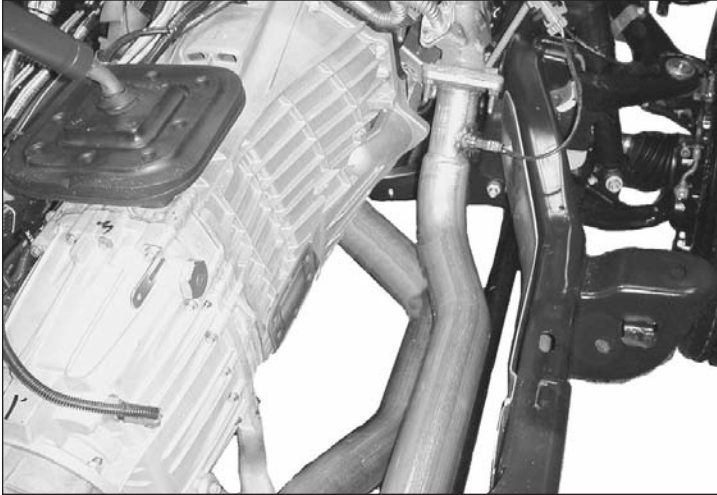

5. The vehicle floorboard shield extends into the PTO install area. Detach the rear of this shield and remove or push out of the way.
6. Caution: Transmission fluid may be HOT. Drain fluid from transmission by removing the drain plug. Remove PTO cover and clean PTO mounting surface, taking care not to let contamination fall into PTO opening. A clean shop rag can be used for additional protection. Remove shop rag when finished.

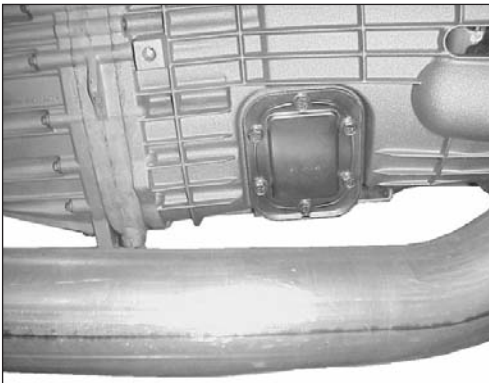

7. Install PTO mounting studs provided. (Note: Refer to IN84-03 manual for details.)

8. The TG Series PTO provided for installation with heat shield requires the “shaft high” 3-arrangement. Install the PTO with the “shaft high” arrangement using the copper washers, lock-tabs and hex nuts provided. (Note: Refer to IN84-03 manual for details.)

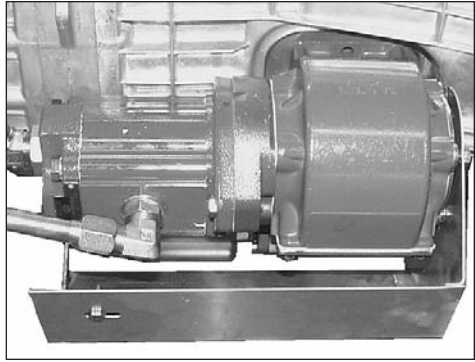

9. Remove the pump housing bolt from the lower right position as shown in this photo and install the heat shield mounting bracket (49T38367). Leave this bolt loose so that it can be positioned to the heat shield.

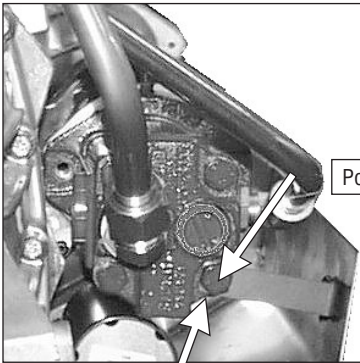

Remove Housing Bolt to Attach Bracket

Position Bracket for Shield Mounting

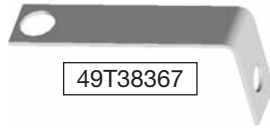

49T38367

10. Install the hydraulic fittings into the PF1 Series pump. The 90° elbow is installed into the side pressure port of the PF1 pump and the 45° fitting is installed into the rear inlet port of the pump.

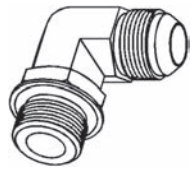

43T38392
-10 Str. Thd./ -10 JIC

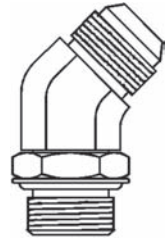

43T38506
-12 Str. Thd./ -12 JIC

11. The PF1 Series pump is installed on the PTO with off-set positioned down.

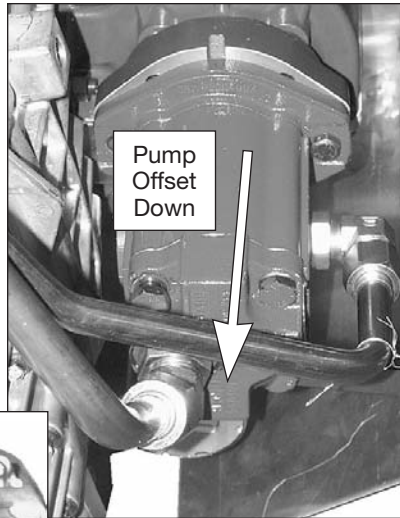

12. Locate the boss at the upper rear of the transmission case and mount the hydraulic line support bracket using 19T32740 (5/16" x 1") capscrew and 22T37605 whiz-loc nut.

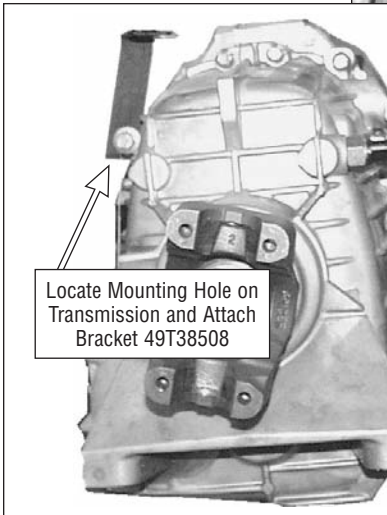

49T38508

13. Install the suction line and pressure line assemblies to the pump and attach to the support bracket using u-clamps provided. Attach u-clamps with single 3/8" x 1" capscrew (19T20522) and nut (22T21723).



Pump Pressure Line



Pump Suction Line

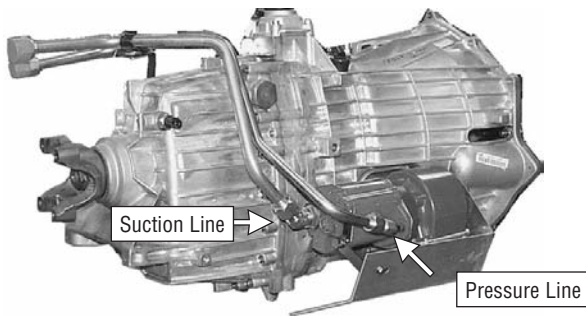
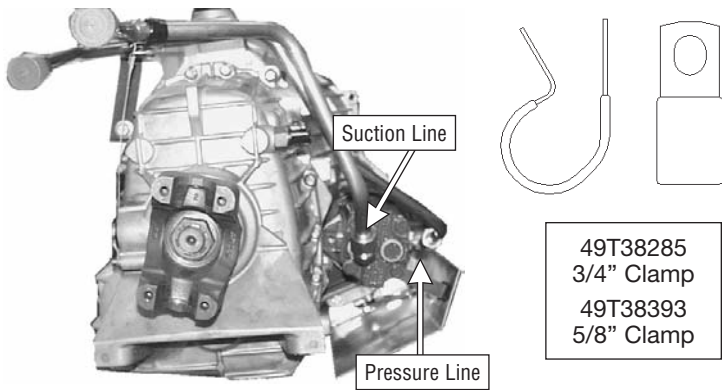

14. Installation of the PTO shifter controls should be done prior to the installation of the heat shield. Review steps 16 & 17 before starting. Hold the shield in place to determine suitable clearance for the controls and clearance from other vehicle components. Install the PTO shifter controls as described in the PTO Owner's Manual IN84-03.
15. Remove two capscrews from the closed bearing cover at the positions indicated in the figure below. Using the spacers provided and capscrews, attach the large heat shield.

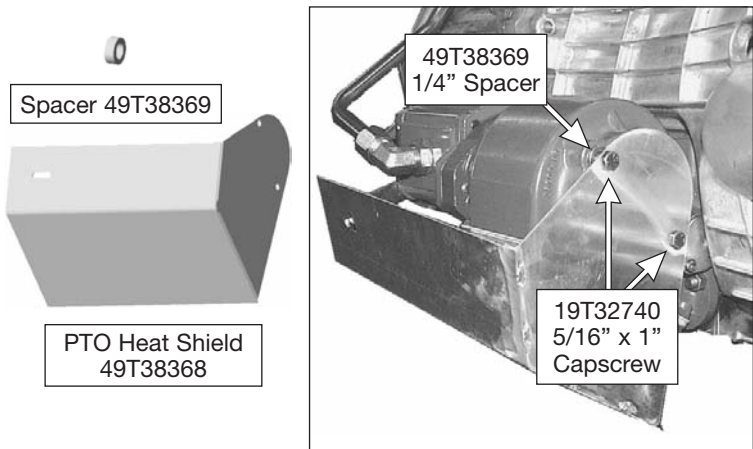

- 16.** Attach the heat shield to the pump bracket which was installed on the Pump in step 10. Tighten the pump bolt to torque specifications of the Pump. (PF1 Series pump 55 lbs.ft.)

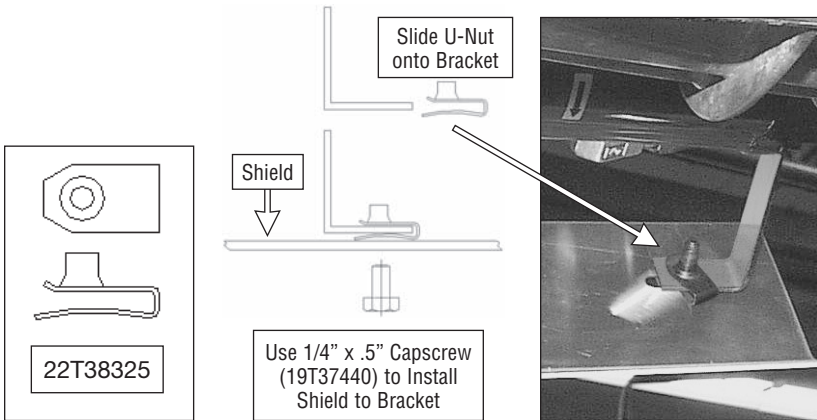

- 17.** Locate the 10 pin connector power take-off harness secured to the transmission by the fuel feed and evaporative emission and return hose bracket at the upper driver's side of the transmission. The plug is inserted into a cap for storage as delivered by G.M.

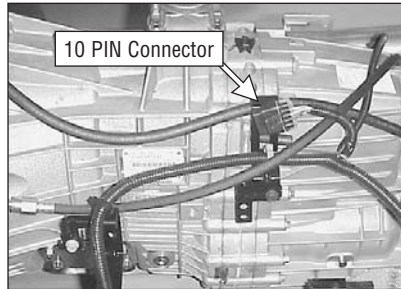

- 18.** The harness 34T38379 is assembled according to the specification chart below. The blunt cut wires are for remote functions and are not used for PTO activation.

PIN	Circuit	Color	Description	Function
B	494A	Light blue	Power Take-Off switch – output – fault	Used for engine disable switch output
C	488A	Light green	Power Take-Off switch – output – enable	Remote set speed switch input
D	550A	Black	Ground	Ground
G	2522A	Yellow	Power Take-Off switch – signal status	Used for Power Take-Off engaged feedback*
H	2561A	White	Power Take-Off replay – output – N.O. contact	Used to supply switched power to Power Take-Off
J	84A	Dark Blue	Cruise Control switch – signal – set/coast	Remote set speed switch output

* Required to turn power take off switch request LED from flashing to steady. Also used to disable OBDII diagnostics when the power take off is operating.

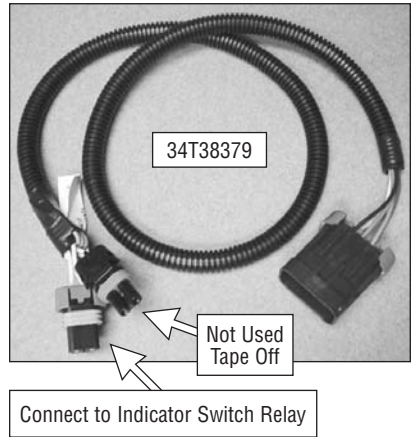
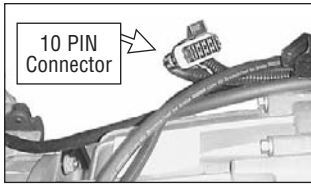

19. Plug the 10 pin connector on the wire harness supplied, into the transmission connector.
20. The other end of the harness has two plugs. For connection to the TG PTO use (1) 34T38527 and connect it to the Metri-Pack plug on the GM harness.

- 21a. Connect additional wire to this harness and route to the vehicle cab for attachment to the indicator switch relay.

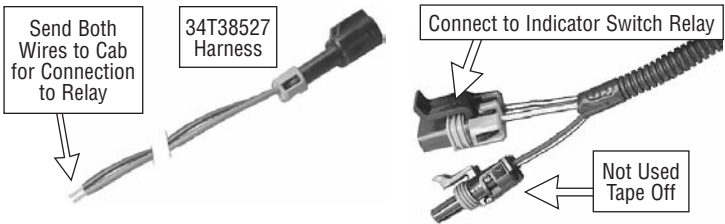

- 21b. For Cable Shift PTO attach a ring terminal to one of the indicator light leads for connection to a 12v dc power source. Attach 1/4" spade connectors to the two wires from the 34T38527 harness. Attach the lead from terminal "A" to pin #87 on the relay. Attach the lead from terminal "B" to pin #30 on the relay. Also, connect a jumper wire from this terminal (30) to pin #85. Attach a spade terminal to a wire lead and route this wire from pin #86 to the PTO and lice it with the connector to the PTO indicator switch. With the connection at #86 connect the other lead of indicator light.

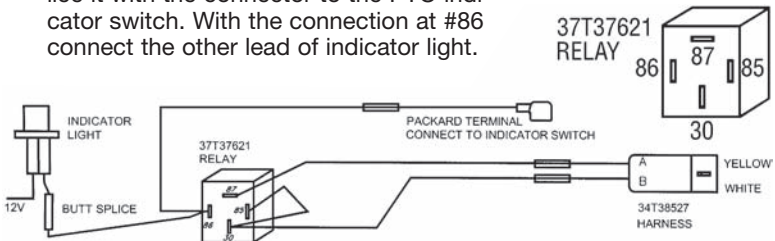

- 21c.** For Lectra Shift applications the connection is made by using 34T38527 harness and connecting with terminal “A” to pin #87 on relay and terminal “B” to pin #30 on relay. Connect a jumper wire from pin #30 and #85. Connect a wire lead from pin #86 and using a scotch clip, attach to the “yellow” wire on the PTO activation switch. The rest of the install is as shown in manual IN98-03.

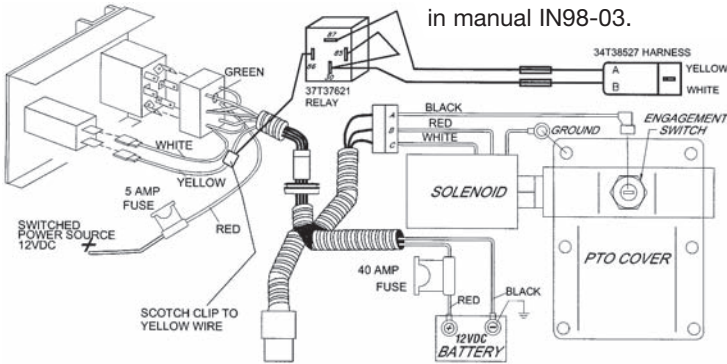

- 22.** Refill transmission to proper level, with oil recommended by manufacturer.
- 23.** Re-install the exhaust pipes, if they were removed from an earlier step.
- 24. IMPORTANT:** Before activating the PTO the remainder of the hydraulic system must be installed and connected, including hydraulic reservoir, control valves, and hydraulic oil. **DO NOT** operate PTO until the hydraulic system is completed and hydraulic system is properly filled with oil. Complete installation by placing warning labels as indicated on decal borders. Placement examples are shown in the PTO owner’s Manual IN84-03.
- 25.** After installation of the hydraulic system and filling the reservoir with the proper hydraulic fluid operate the system and listen for noise. It is a common occurrence that this PTO system will produce some noise. Most of this noise can be attributed to the total drivetrain torsional vibration which is transmitted through the components and amplified by the heat shield system installed around and to the PTO. When the hydraulic system is energized and placed under a load this noise should greatly diminish. If this is the case then the noise should not be detrimental to the application. If not then double check that you have used the proper mounting backlash to mount the PTO. Remove PTO for inspection of transmission and PTO.
- 26.** To operate the PTO be sure that the engine is at idle speed. Engage the PTO as described in the PTO owner’s manual for the type of shifter control you have installed. After the PTO is engaged turn the PTO switch to the “On” position.
- 27.** Below are operating instructions for the switch and throttle advance.
- 28.** The vehicle is supplied from the Dealer with the preset throttle option. If you desire the variable throttle option the vehicle control module will need to be changed by the Dealer.

POWER TAKE OFF SWITCH INSTALLATION INSTRUCTIONS

*Install the GM activation switch into the dash
by following the instructions below:*

30T37620 Power take off switch

34T40299 Wiring harness

SWITCH INSTALLATION INSTRUCTIONS

1. Apply parking brake to prevent the vehicle from moving.
2. If equipped with an automatic transmission, move the shift lever all the way down to the last gear.
3. Tilt the steering wheel to the full down position.
4. Pull gently on the corners of the instrument panel trim plate trim plate to remove it. (Figure A)
5. Find the switch accessory housing to the right of the heating and air controls. (Figure B)
6. Remove switch accessory housing and the lower left switch accessory cover from the housing. The switch accessory housing is snapped into the instrument panel retainer.
7. Install the Power Take-Off switch.
8. Locate the power take-off switch harness from behind the dash. (Figure C) The Muncie wiring harness has the matching connector.
9. You may cut a hole in the accessory panel housing for the rocker switch or use the supplied bracket to mount the Muncie rocker switch. Replace the switch accessory housing into the instrument panel.
10. Attach bezel to the instrument panel assembly by aligning the guide pins and pushing gently on the bezel until it is in place.
11. Ensure that all instrument panel bezel retaining clips are in place and tilt the steering wheel to the normal drive position.
12. Move the shift lever to the park position.

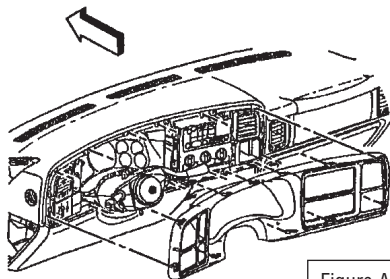

Figure A

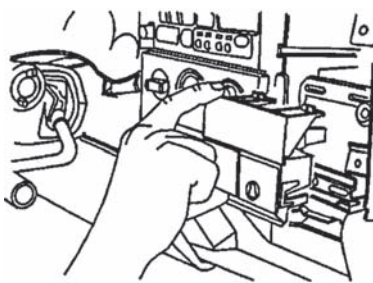

Figure B

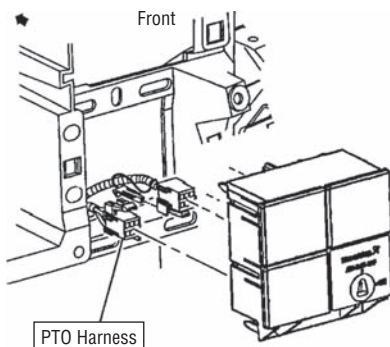

Figure C

PTO OPERATION

Muncie TG Series PTO (Manual Transmission)

Using PTO speed control in Preset Mode (Factory Default Setting):

1. PTO engaged.
2. Applying Park Brake, Select NEUTRAL (N) Range.
3. Foot off brake pedal (and off clutch for manual transmission).
4. Select desired engine speed for PTO operation. Please read the following Preset Mode section regarding operation.

Preset Mode:

The PTO switch has a “momentary” position which is the “SET” function. Press to set the vehicle into ramp up speed control. PTO speed control mode used for stationary applications (PTO will remain engaged while mobile in the preset mode however PTO set and resume speed controls will be inoperative). This mode provides a default standby speed of 800 or 850 rpm (depending on the engine/transmission combination) and two default PTO control speeds: PTO Set Speed of 1250 rpm, and PTO Resume Speed of 1700 rpm. Please note that the standby speed (800/850 rpm) is not to be used as a PTO control speed. Vehicles not equipped with cruise control will not have the resume speed capability. The graphics on the following page depict how to achieve the desired speeds with the set and resume switches.

Achieving the desired speeds with the set and resume switches:

Vehicles w/o Cruise Control

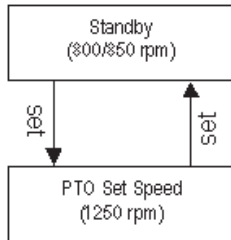

Cruise Equipped Vehicles

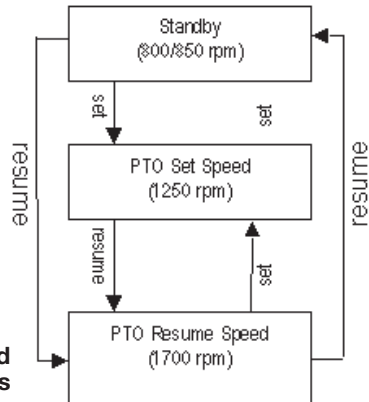

Variable Mode:

PTO speed control mode used for both stationary and mobile applications. This mode allows PTO to be controlled in a fashion similar to which a cruise control controls vehicle speed. The operator can set to a RPM (between 800 and 2200) with the set switch on the cruise stalk or with the set position on the PTO switch. The operator is then able to “tap up” in 100 rpm increments with the resume switch on the cruise stock or “tap down” with either set switch (on the cruise stalk or the PTO rotary switch). Vehicles not equipped with cruise control will not have the “tap up” capability.



Using PTO speed control in Variable Mode (while Mobile):

1. PTO engaged.
2. Vehicle speed greater than 5 mph.
3. Foot off brake pedal (and off clutch for manual transmission).
4. Obtain desired engine speed (with foot pedal) and select set on the PTO rotary switch or the cruise stock.

Using PTO speed control in Variable Mode (while Stationary):

1. PTO engaged.
2. Vehicle speed less than 5 mph.
3. Foot off brake pedal (and off clutch for manual transmission).
4. Obtain desired engine speed (with foot pedal) and select set on the PTO rotary switch or the cruise stock.

Note: All engine speed values listed above are factory default values. With the exception of the “tap” increment (100 rpm) all of these values are programmable and can be adjusted by your GM dealer or body upfitter with a Tech-2 service tool. If your vehicle PTO software settings do not match the settings shown here then they may have already been altered by the body upfitter in order to satisfy the requirements of the installed PTO system and body equipment.



**Muncie[®]
Power
Products**

Muncie Power Products, Inc. *Member of the Interpump Hydraulics Group*
General Offices and Distribution Center • P.O. Box 548 • Muncie, IN 47308-0548 • (765) 284-7721
FAX (765) 284-6991 • E-mail info@munciepower.com • Web site <http://www.munciepower.com>
Drive Products, Exclusive Agents for Canada, *ISO Certified by an Accredited Registrar*

IN01-05 (Rev. 1-10) Printed in the U.S.A.